

TubeJet® Pulse-Cleaned Dust Collectors



Square Series – SBR Side Bag Removal Dust Collectors

- 50-50,000 ACFM Capacities
- 20" w.g. to 80" w.g. design pressures
- Construction to 500°F design temperature

When headroom is tight, these collectors can fit where top removal units can't. Side door provides access for bag change-outs. These are outstanding collectors for bin vent applications.

Also available:

PV Series

Standard bin vents pre-engineered with:

- Roof flange for fan mounting
- Man grid
- Angle base

OSHA-compliant
combustible
dust explosion
protection per
NFPA 654, 68 & 69

Optimum Pulse-Cleaning

- Adjustable solid state timer for fine tuning cleaning system
- On-demand cleaning to reduce compressed air consumption (optional)
- Varying pulse valve sizes matched to filter bags (length, number of bags)

High Filtration Efficiency

- Wide range of bag fabrics and finishes
- Pleated bag designs available

Custom Design Options

- Configurable hopper slope/discharge
- 6" nominal diameter bag diameter (optional 4-1/2" diameter for light bulk density applications)
- Roof/side-mounted fans

Inlet Options

- High side inlet

Sly Standard Construction Benefits

- Radial low velocity dual stage inlet with diffuser decreases turbulence
- 12 vertical wire cage provides extra support, minimizing bag wear

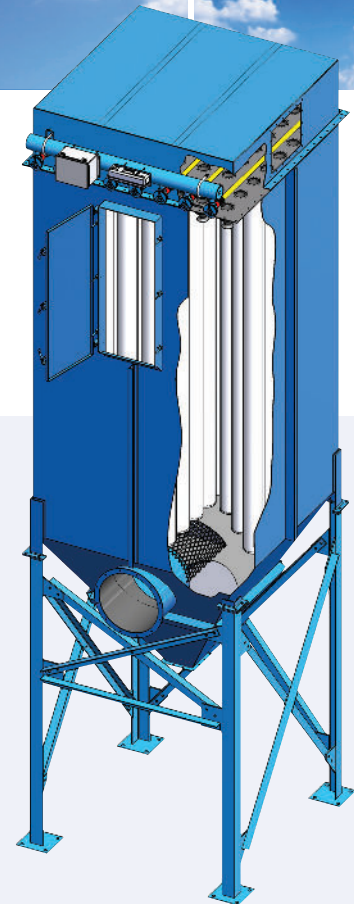

Options

- Supports designed to ASCE-7
- Access platforms
- Blowers
- Discharge valves
- Explosion protection
- Sprinklers
- Carbon, stainless or alloy construction
- Man grids

SLY INC

TECHNOLOGY FOR A
CLEAN ENVIRONMENT

8300 Dow Circle, Suite 600, Strongsville, OH 44136

800-334-2957

Fax: (440) 891-3210 E-mail: info@slyinc.com

Web: www.slyinc.com