

Processing Solutions for Recycling & Waste

Carrier Vibrating Equipment designs and manufactures a line of equipment specifically for the unique processing needs of the recycling and waste industries. From vibratory conveyors, feeders and screeners to air knife separators and vibrating fluid bed dryers, our recycling and waste equipment provides high efficiency and long life to keep costs down and revenues up.

Carrier's heavy-duty equipment supports recycling operators all over the world with reliable processing technology. Our equipment has been used for scrap and waste materials including UBC, metals, electronics, glass, plastics, and construction debris.



Trusted in these Industries over 70 Years

Equipment for Processing Waste & Recycled Materials:

- Vibrating Conveyors
- Vibrating Feeders & Screeners
- Air Knife Separators
- Vibrating Fluid Bed Dryers

Carrier[®]
Vibrating Equipment, Inc.

Vibrating Conveyors

Leaf and coil spring vibrating conveyors easily move scrap, UBC, construction debris, glass, and plastics reliably and efficiently. Our conveyors are multi-functional, combining a number of processes in a single unit, and can also be designed for specific applications.

Features & Benefits

- Multi-functional design in a single unit to convey, feed, heat, cool, scalp, screen, quench, dewater, accumulate, separate and distribute
- Natural frequency design with minimal horsepower requirements
- Leak-proof monolithic troughs eliminate spilling, waste and contamination
- Simple replacement of liners or troughs

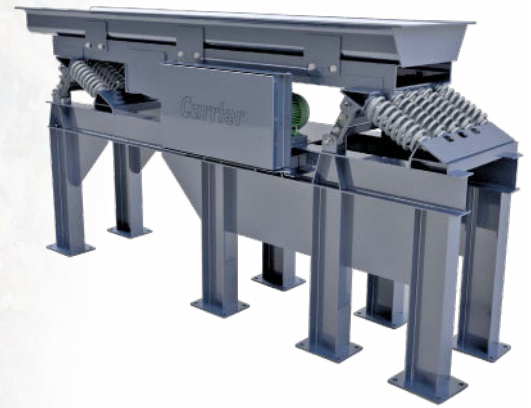

Options

- Quenching conveyors
- Two-way conveying
- Leaf springs or metal coil springs
- Polished troughs & special coatings
- Perforated plates or screens
- Dust-tight designs
- Heating & cooling jackets



Quenching Conveyors

Quenching conveyors with integrated water pools provide continuous processing of glass cullet from melt furnaces.

Vibrating Feeders & Screeners

Feeders deliver efficient, economical metering of bulk solids at a fixed or adjustable feed rate. Screeners are built for a variety of waste materials and can be designed with multiple decks in a single unit to meet exact process requirements.



Screeners for Recycling

Vibrating Feeders

- Natural frequency drive units maintain stroke under extreme headloads for reliable operation
- Fixed or variable feed rates provide versatility for different process requirements

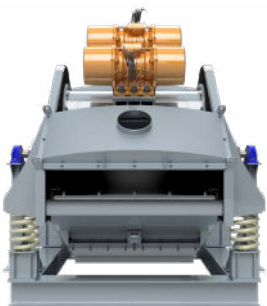

Options

- Polished trough & coatings
- Isolation arrangements
- Fixed or adjustable rate control
- Removable dust-tight covers

Vibrating Screeners

- Multi-functional design for screening, scalping, dewatering or separation
- Vibratory screeners with elliptical or circular motion for increased efficiency



Options

- Multiple screening decks
- Ball decks
- Wire mesh, perforated plate, or wedge wire decks

Air Knife Separators

Air knife separators are an efficient and easy way of separating metal, plastics, paper, and debris from the waste stream. It works by using a vibrating conveyor to move material over a high velocity stream of air, causing heavy materials to drop out while lighter materials are blown into a hopper or exhaust filter.

Features & Benefits

- High-velocity air knife separates plastics, paper & loose dirt from UBC scrap or construction debris
- No moving parts in contact with material to minimize product degradation
- Adjustable nozzle assembly allows fine-tuning

Options

- Single or dual air knife arrangement
- Supply air blower for separation
- Dust collection equipment
- Support structures



Air Knife Arrangements

Air knife separators can be designed with single or double air knife arrangements to maximize efficiency.

Vibrating Fluid Bed Dryers & Coolers

Fluid bed dryers are an ideal and customizable solution for efficiently removing moisture from recycled materials. They can dry a wide variety of recycled materials including UBC aluminum scrap prior to it moving to the furnace and plastics that have been cleaned and washed. Fluid bed dryers and coolers can be designed for any material and any moisture requirement.

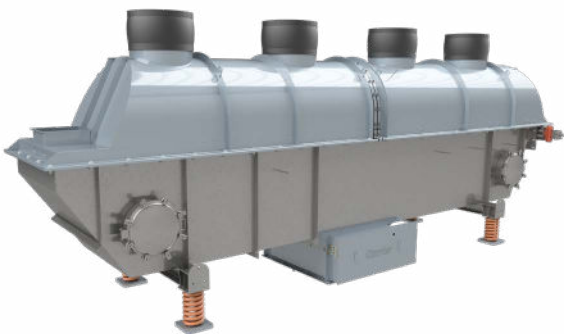

Options

- Custom fluidizing decks
- High-temperature designs
- Access manways & doors
- Custom controls
- Iso-Max™ dynamic reaction reducer

Features & Benefits

- Optimized fluidizing velocity and vibration provides maximum energy efficiency
- Plug flow delivers consistent first-in, first-out output of materials
- High temperature designs provide minimal footprint and maximum efficiency
- Zoning allows multiple functions such as simultaneous drying, classification, and cooling to be performed

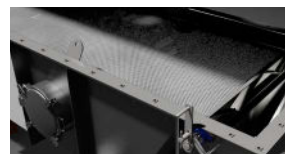

Custom Fluidizing Decks



Engineering & Manufacturing

- Technology profile of over 150 patents
- Equipment designs are verified using Finite Element Analysis (FEA) to ensure trouble-free service and long life
- 3D equipment modeling
- State-of-the-art manufacturing facilities on 3 continents with robotic cutting and welding
- Manufacturing expertise working with mild steel, various grades of stainless steel, duplex steels and other exotic alloys for specialty applications
- Welders certified to ASME & AWS standards
- ISO 9001:2015 certified

Lab Testing

Be confident that your processing is efficient with CPEG's 15,000 ft² state-of-the-art test lab. With our lab, you have access to the most extensive testing capabilities in the industry. Multiple pieces of equipment can be combined for multistep and multistage testing to simulate field operation, validate new equipment designs and provide complete process solutions. Combined with our full analysis of material characteristics and measurements of material behavior in specific processing applications, you are assured an efficient, reliable and safe solution, all backed by our process warranty. Field testing with rental equipment is available when lab testing would not effectively simulate process operating environments.

Aftermarket Parts & Services

Carrier offers a full line of aftermarket parts for its equipment. Our Aftermarket Sales Team will assess your parts needs and recommend the best solution. Our engineers are available to assist in any redesign or retrofit your existing equipment for new applications.

AMERICAS

Carrier Vibrating Equipment, Inc.
3400 Fern Valley Rd
Louisville, KY 40213, United States
Tel: +1-502-969-3171 | Fax: +1-502-969-3172
carriervibrating.com | cve@carriervibrating.com

EUROPE

Carrier Europe SA
Rue Joseph Luns 52
B-1401 Nivelles, Belgium
Tel: +32 67 40 01 40
carriereurope.be | ceur@carriereurope.be

CHINA

Carrier Vibrating Equipment (Shanghai) Co., Ltd.
#1 Bldg., #88 Shenzhou Road, Fengcheng Town
Fengxian District | Shanghai, 201411 China
Tel: +86 21-33925800
cves@carriervibrating.com.cn



A Division Of **CPEG** CARRIER VIBRATING EQUIPMENT GROUP INC.



© 2022 Carrier Vibrating Equipment, Inc. CVE-SRW-0123